

G-G (10:1)

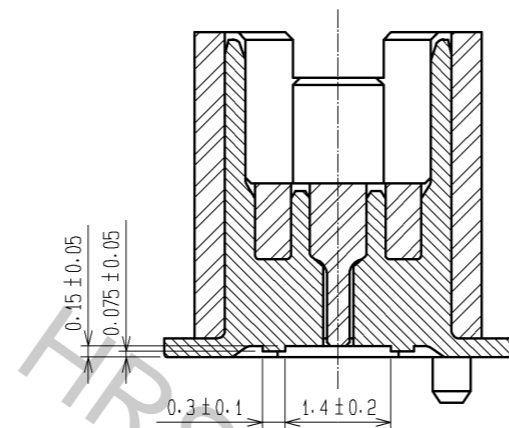

CODE No.	CONTACT	A	B	C	D	E	F
CL537-0478-3-81	20	7.2	4.5	5.3	5.7	6.6	5.3
CL537-0480-5-81	30	9.7	7.0	7.8	8.2	9.1	7.8
CL537-0481-8-81	36	11.2	8.5	9.3	9.7	10.6	9.3
CL537-0482-0-81	40	12.2	9.5	10.3	10.7	11.6	10.3
CL537-0484-6-81	50	14.7	12.0	12.8	13.2	14.1	12.8
CL537-0486-1-81	60	17.2	14.5	15.3	15.7	16.6	15.3

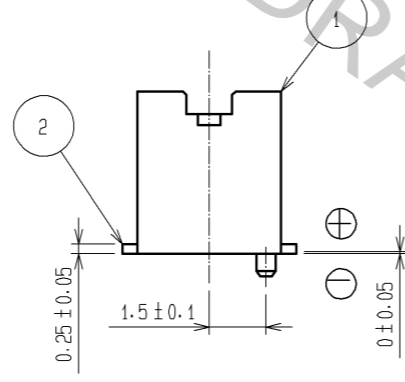
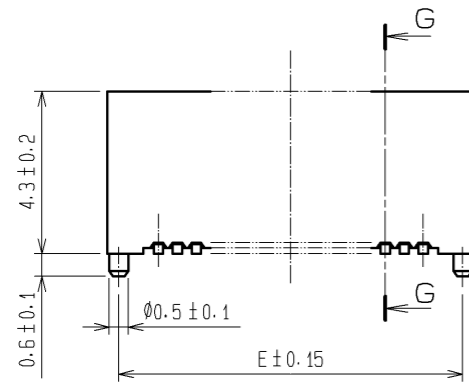

RECOMMEND METAL MASK PATTERN (10:1)

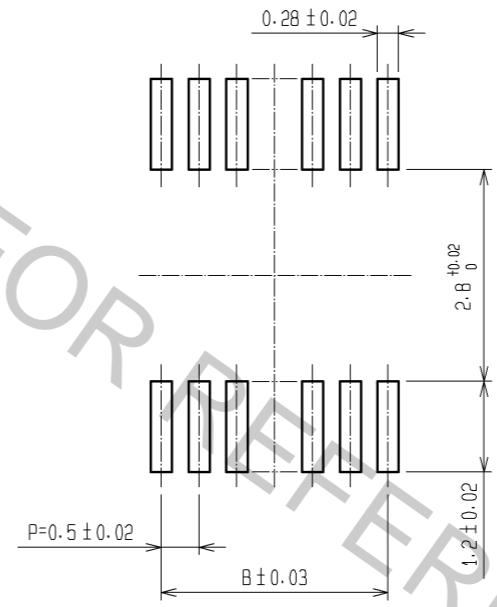

RECOMMENDED LAND PATTERN (10:1)

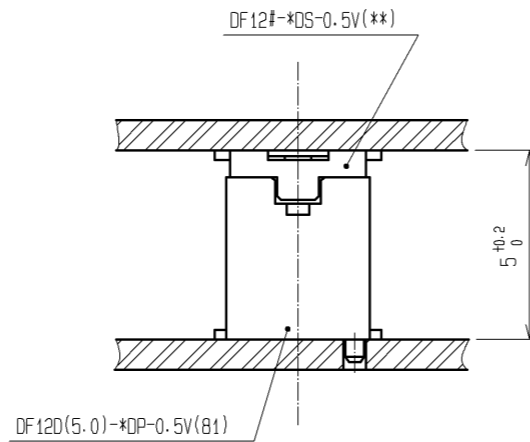
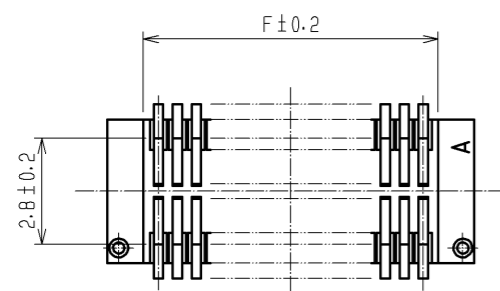
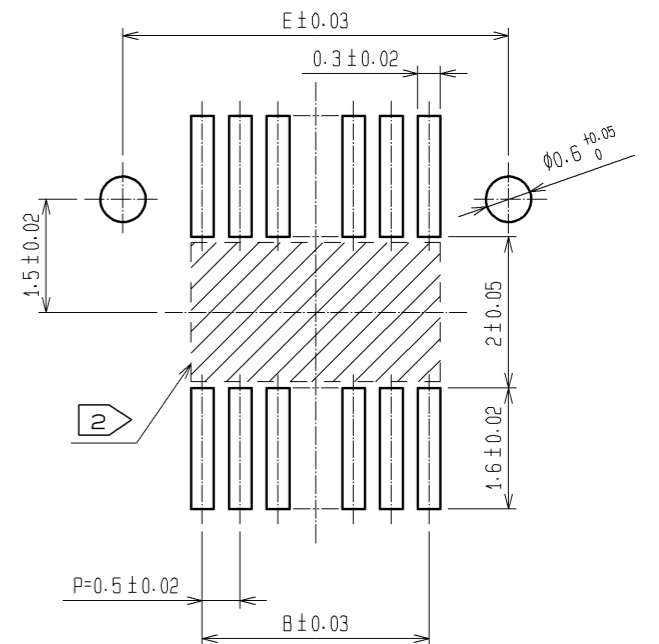

RECOMMENDED THICKNESS OF METAL MASK : 120 μm

RECOMMENDED THICKNESS OF SOLDER PASTE : 120 μm

NOTES 1 LEAD CO-PLANARITY SHALL BE 0.08 mm MAX.
 2 IF THERE IS PATTERN ON [Hatched] PART, THERE IS A POSSIBILITY THAT IT WILL MAKE CONTACT WITH THE LEADS.

NO.	MATERIAL	FINISH	REMARKS	NO.	MATERIAL	FINISH	REMARKS
2	PHOSPHOR BRONZE		CONTACT AREA:GOLD PLATED 0.2μm min LEAD AREA:GOLD PLATED 0.015μm min OTHERS(UNDER PLATING):NICKEL PLATED 2μm min	6	PS		CLEAR (REINFORCEMENT COLLAR)
				5	PS		BLACK (PLASTIC REEL)
				4	POLYESTER		CLEAR (COVER TAPE)
1	POLYAMIDE		UL94V-0-NATURAL(BEIGE)	3	PS		CLEAR (EMBOSSED CARRIER TAPE)

UNITS	SCALE	COUNT	DESCRIPTION OF REVISIONS	DESIGNED	CHECKED	DATE
mm	5 : 1	△				

APPROVED : KH. IKEDA	13.08.19	DRAWING NO.	EDC3-163515-77
CHECED : YH. MICHIDA	13.08.09	PART NO.	DF12D(5.0)-*DP-0.5V(81)
DESIGNED : YN. SAKAMOTO	13.08.08	CODE NO.	CL537
DRAWN : KR. AJITO	13.08.08		

May.1.2017 Copyright 2017 HIROSE ELECTRIC CO., LTD. All Rights Reserved.

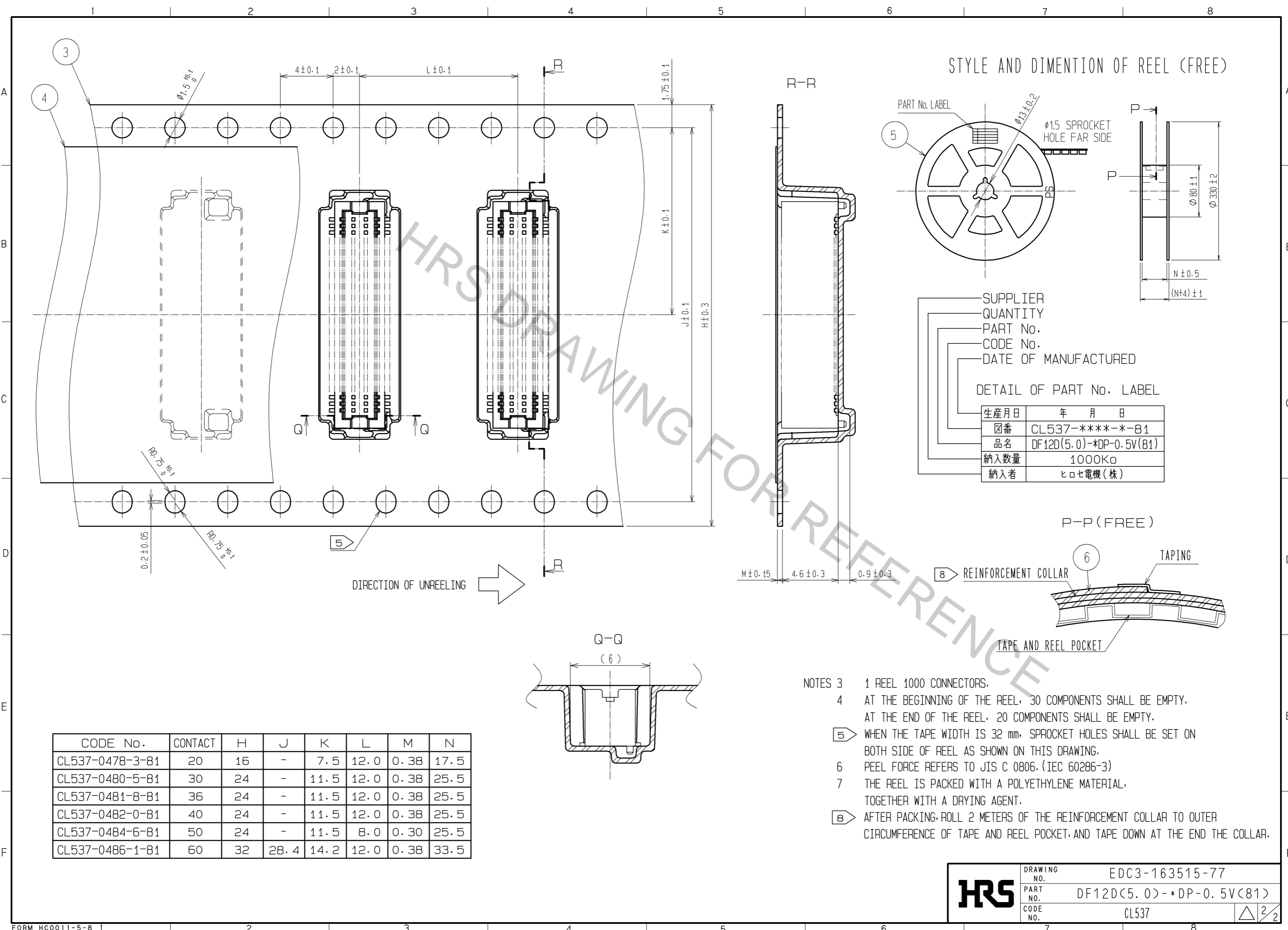

STYLE AND DIMENTION OF REEL (FREE)

SUPPLIER
 QUANTITY
 PART No.
 CODE No.
 DATE OF MANUFACTURED

DETAIL OF PART No. LABEL

生産月日	年 月 日
図番	CL537-****-*-81
品名	DF12D(5.0)-*DP-0.5V(81)
納入数量	1000Kφ
納入者	ヒロセ電機(株)

- NOTES
- 3 1 REEL 1000 CONNECTORS.
 - 4 AT THE BEGINNING OF THE REEL, 30 COMPONENTS SHALL BE EMPTY. AT THE END OF THE REEL, 20 COMPONENTS SHALL BE EMPTY.
 - 5 WHEN THE TAPE WIDTH IS 32 mm, SPROCKET HOLES SHALL BE SET ON BOTH SIDE OF REEL AS SHOWN ON THIS DRAWING.
 - 6 PEEL FORCE REFERS TO JIS C 0806. (IEC 60286-3)
 - 7 THE REEL IS PACKED WITH A POLYETHYLENE MATERIAL, TOGETHER WITH A DRYING AGENT.
 - 8 AFTER PACKING, ROLL 2 METERS OF THE REINFORCEMENT COLLAR TO OUTER CIRCUMFERENCE OF TAPE AND REEL POCKET, AND TAPE DOWN AT THE END THE COLLAR.

CODE No.	CONTACT	H	J	K	L	M	N
CL537-0478-3-81	20	16	-	7.5	12.0	0.38	17.5
CL537-0480-5-81	30	24	-	11.5	12.0	0.38	25.5
CL537-0481-8-81	36	24	-	11.5	12.0	0.38	25.5
CL537-0482-0-81	40	24	-	11.5	12.0	0.38	25.5
CL537-0484-6-81	50	24	-	11.5	8.0	0.30	25.5
CL537-0486-1-81	60	32	28.4	14.2	12.0	0.38	33.5

HRS	DRAWING NO.	EDC3-163515-77
	PART NO.	DF12D(5.0)-*DP-0.5V(81)
	CODE NO.	CL537
		△ 2/2