

PCK9446

2.5 V and 3.3 V LVCMOS clock fan-out buffer

Rev. 01 — 10 April 2006

Product data sheet

1. General description

The PCK9446 is a 2.5 V and 3.3 V compatible 1 : 10 clock distribution buffer designed for low-voltage mid-range to high-performance telecom, networking and computing applications. Both 3.3 V, 2.5 V and dual supply voltages are supported for mixed-voltage applications. The PCK9446 offers 10 low skew outputs and 2 selectable inputs for clock redundancy. The outputs are configurable and support 1 : 1 and 1 : 2 output to input frequency ratios. The PCK9446 is specified for the extended temperature range of $-40\text{ }^{\circ}\text{C}$ to $+85\text{ }^{\circ}\text{C}$.

The PCK9446 is a full static design supporting clock frequencies up to 250 MHz. The signals are generated and retimed on-chip to ensure minimal skew between the three output banks. Two independent LVCMOS compatible clock inputs are available. This feature supports redundant clock sources or the addition of a test clock into the system design. Each of the three output banks can be individually supplied by 2.5 V or 3.3 V supporting mixed voltage applications. The FSELx pins choose between division of the input reference frequency by one or two. The frequency divider can be set individually for each of the three output banks. The PCK9446 can be reset and the outputs are disabled by deasserting the MR/ $\overline{\text{OE}}$ pin (logic HIGH state). Asserting $\overline{\text{OE}}$ will enable the outputs.

All inputs accept LVCMOS signals while the outputs provide LVCMOS compatible levels with the capability to drive terminated $50\ \Omega$ transmission lines. Please refer to the PCK9456 specification for a 1 : 10 mixed voltage buffer with LVPECL compatible inputs. For series terminated transmission lines, each of the PCK9446 outputs can drive one or two traces giving the devices an effective fan-out of 1 : 20. The device is packaged in a 32-lead LQFP package which has a $7\text{ mm} \times 7\text{ mm}$ body size with a conservative 0.8 mm pin spacing.

2. Features

- Configurable 10 outputs LVCMOS clock distribution buffer
- Compatible to single, dual and mixed 3.3 V/2.5 V voltage supply
- Wide range output clock frequency up to 250 MHz
- Designed for mid-range to high-performance telecom, networking and computer applications
- Supports applications requiring clock redundancy
- Maximum output skew of 200 ps (100 ps within one bank)
- Selectable output configurations per output bank
- 3-stateable outputs
- 32-lead LQFP packaging
- Ambient operating temperature range of $-40\text{ }^{\circ}\text{C}$ to $+85\text{ }^{\circ}\text{C}$

PHILIPS

3. Ordering information

Table 1. Ordering information

Type number	Package		Version
	Name	Description	
PCK9446BD	LQFP32	plastic low profile quad flat package; 32 leads; body 7 × 7 × 1.4 mm	SOT358-1

4. Functional diagram

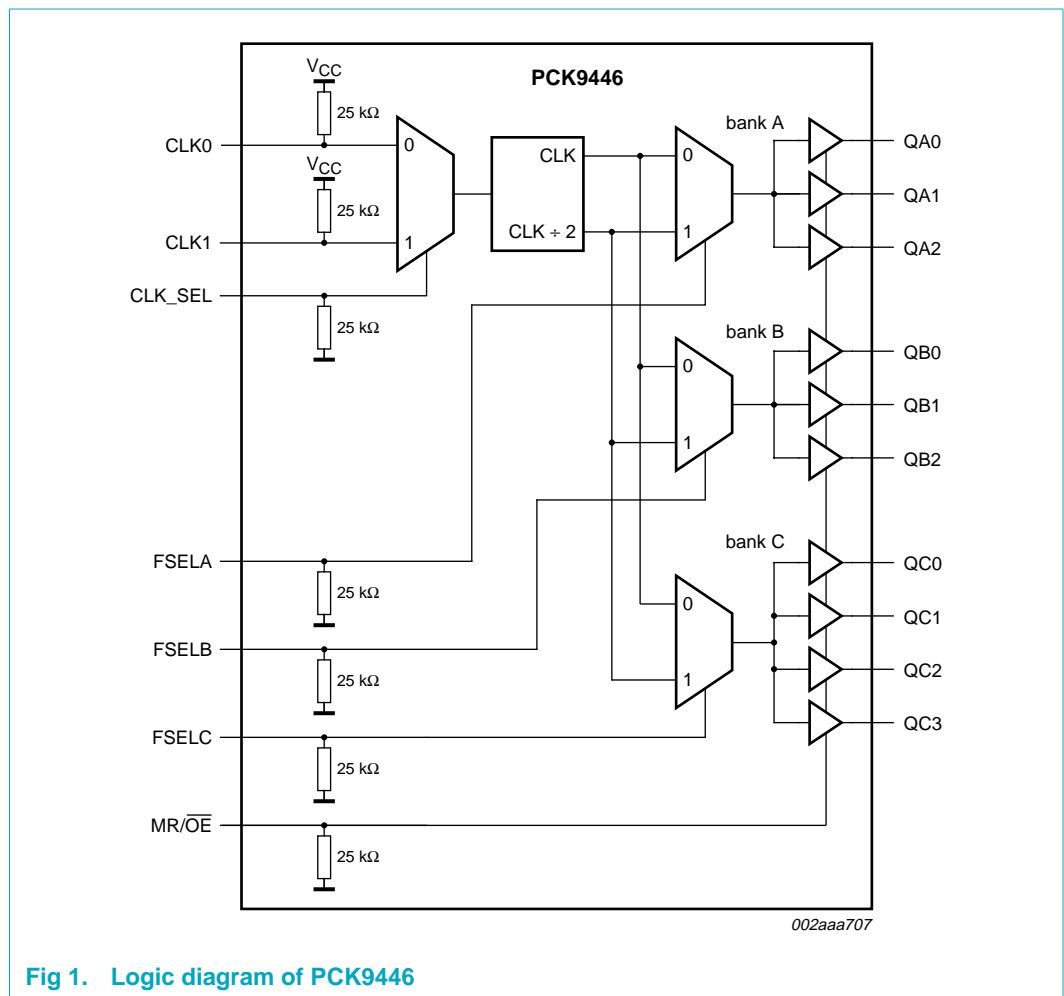

Fig 1. Logic diagram of PCK9446

5. Pinning information

5.1 Pinning

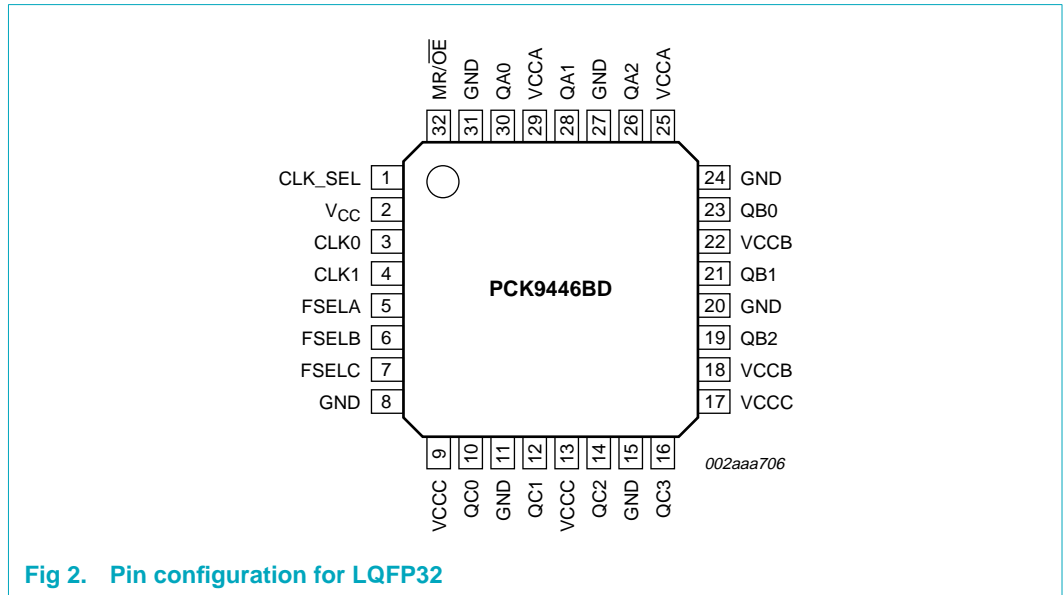

Fig 2. Pin configuration for LQFP32

5.2 Pin description

Table 2. Pin description

Symbol	Pin	I/O	Type	Description
CLK_SEL	1	I		clock input select
CLK0, CLK1	3, 4	I	LVCMOS	LVCMOS clock inputs
FSELA, FSELB, FSEL C	5, 6, 7	I	LVCMOS	output bank divide select input
MR/ \overline{OE}	32	I	LVCMOS	internal reset and output 3-State control
GND	8, 11, 15, 20, 24, 27, 31		supply	negative voltage supply output bank (GND)
VCCA	25, 29		supply	positive voltage supply for output bank A
VCCB ^[1]	18, 22		supply	positive voltage supply for output bank B
VCCC	9, 13, 17		supply	positive voltage supply for output bank C
V _{CC}	2		supply	positive voltage supply core (V _{CC})
QA[0:2]	30, 28, 26	O	LVCMOS	bank A outputs
QB[0:2]	23, 21, 19	O	LVCMOS	bank B outputs
QC[0:3]	10, 12, 14, 16	O	LVCMOS	bank C outputs

[1] VCCB is internally connected to V_{CC}.

6. Functional description

Refer to [Figure 1 “Logic diagram of PCK9446”](#).

6.1 Function table

Table 3. Function table (controls)

Control	Default	Value	
		0	1
CLK_SEL	0	CLK0	CLK1
FSELA	0	frequency on bank A outputs = f_{ref}	frequency on bank A outputs = $f_{ref} \div 2$
FSELB	0	frequency on bank B outputs = f_{ref}	frequency on bank B outputs = $f_{ref} \div 2$
FSELC	0	frequency on bank C outputs = f_{ref}	frequency on bank C outputs = $f_{ref} \div 2$
MR/ \overline{OE}	0	outputs enabled	internal reset outputs disabled (3-state)

6.2 Supply configurations

Table 4. Supported single and dual supply configurations

Supply voltage configuration	V_{CC} ^[1]	$V_{CC(\text{bankA})}$ ^[2]	$V_{CC(\text{bankB})}$ ^[3]	$V_{CC(\text{bankC})}$ ^[4]	GND
3.3 V	3.3 V	3.3 V	3.3 V	3.3 V	0 V
mixed voltage supply	3.3 V	3.3 V or 2.5 V	3.3 V	3.3 V or 2.5 V	0 V
2.5 V	2.5 V	2.5 V	2.5 V	2.5 V	0 V

[1] V_{CC} is the positive power supply of the device core and input circuitry. V_{CC} voltage defines the input threshold and levels.

[2] $V_{CC(\text{bankA})}$ is the positive power supply of the bank A outputs (VCCA pins). $V_{CC(\text{bankA})}$ voltage defines bank A output levels.

[3] $V_{CC(\text{bankB})}$ is the positive power supply of the bank B outputs (VCCB pins). $V_{CC(\text{bankB})}$ voltage defines bank B output levels. V_{CCB} is internally connected to V_{CC} .

[4] $V_{CC(\text{bankC})}$ is the positive power supply of the bank C outputs (VCCC pins). $V_{CC(\text{bankC})}$ voltage defines bank C output levels.

7. Limiting values

Table 5. Limiting values

In accordance with the Absolute Maximum Rating System (IEC 60134).

Symbol	Parameter	Conditions	Min	Max	Unit
V_{CC}	supply voltage		-0.3	+4.6	V
V_I	input voltage		-0.3	$V_{CC} + 0.3$	V
V_O	output voltage		-0.3	$V_{CC} + 0.3$	V
I_I	input current		-	± 20	mA
I_O	output current		-	± 50	mA
T_{stg}	storage temperature		-40	+125	°C

8. Recommended operating conditions

Table 6. Operating conditions

Symbol	Parameter	Conditions	Min	Typ	Max	Unit
V_{CC}	supply voltage		2.375	-	3.465	V
$V_{CC(\text{bankA})}$	supply voltage (bank A)	VCCA pins	2.375	-	3.465	V
$V_{CC(\text{bankB})}$	supply voltage (bank B)	VCCB pins	2.375	-	3.465	V
$V_{CC(\text{bankC})}$	supply voltage (bank C)	VCCC pins	2.375	-	3.465	V
T_{amb}	ambient temperature		-40	-	+85	°C

9. Static characteristics

Table 7. Static characteristics (3.3 V)

$T_{amb} = -40\text{ }^{\circ}\text{C to } +85\text{ }^{\circ}\text{C}$; $V_{CC} = V_{CC(bankA)} = V_{CC(bankB)} = V_{CC(bankC)} = 3.3\text{ V} \pm 5\%$.

Symbol	Parameter	Conditions	Min	Typ	Max	Unit
V_{IH}	HIGH-level input voltage	CLK0, CLK1; LVCMOS	2.0	-	$V_{CC} + 0.3$	V
V_{IL}	LOW-level input voltage	CLK0, CLK1; LVCMOS	-0.3	-	+0.8	V
V_{OH}	HIGH-level output voltage	$I_{OH} = -24\text{ mA}$	[1] 2.4	-	-	V
V_{OL}	LOW-level output voltage	$I_{OL} = 24\text{ mA}$	[1] -	-	0.55	V
		$I_{OL} = 12\text{ mA}$	-	-	0.30	
I_I	input current		[2] -	-	± 200	μA
C_i	input capacitance		-	4.0	-	pF
C_{PD}	power dissipation capacitance	per output	-	10	-	pF
$I_{q(max)}$	maximum quiescent current	all VCCx pins	-	-	0.5	mA
Z_o	output impedance		-	(14 to 17)	-	Ω
V_T	termination voltage	output	-	$0.5V_{CC}$	-	V

[1] The PCK9446 is capable of driving 50 Ω transmission lines on the incident edge. Each output can drive one 50 Ω parallel terminated transmission line to a termination voltage of V_T . Alternately, the device drives up to two 50 Ω series terminated transmission lines.

[2] Input pull-up/pull-down resistors influence input current.

Table 8. Static characteristics (2.5 V)

$T_{amb} = -40\text{ }^{\circ}\text{C to } +85\text{ }^{\circ}\text{C}$; $V_{CC} = V_{CC(bankA)} = V_{CC(bankB)} = V_{CC(bankC)} = 2.5\text{ V} \pm 5\%$.

Symbol	Parameter	Conditions	Min	Typ	Max	Unit
V_{IH}	HIGH-level input voltage	LVCMOS	1.7	-	$V_{CC} + 0.3$	V
V_{IL}	LOW-level input voltage	LVCMOS	-0.3	-	+0.7	V
V_{OH}	HIGH-level output voltage	$I_{OH} = -15\text{ mA}$	[1] 1.8	-	-	V
V_{OL}	LOW-level output voltage	$I_{OL} = 15\text{ mA}$	-	-	0.6	V
I_I	input current		-	-	± 200	μA
C_i	input capacitance		-	4.0	-	pF
C_{PD}	power dissipation capacitance	per output	-	10	-	pF
$I_{q(max)}$	maximum quiescent current	all VCCx pins	-	-	0.5	mA
Z_o	output impedance		-	(17 to 20)	-	Ω
V_T	termination voltage	output	-	$0.5V_{CC}$	-	V

[1] The PCK9446 is capable of driving 50 Ω transmission lines on the incident edge. Each output can drive one 50 Ω parallel terminated transmission line to a termination voltage of V_T . Alternately, the device drives up to two 50 Ω series terminated transmission lines.

10. Dynamic characteristics

Table 9. Dynamic characteristics (3.3 V)

$T_{amb} = -40\text{ }^{\circ}\text{C}$ to $+85\text{ }^{\circ}\text{C}$; $V_{CC} = V_{CC(bankA)} = V_{CC(bankB)} = V_{CC(bankC)} = 3.3\text{ V} \pm 5\%$.^[1]

Symbol	Parameter	Conditions	Min	Typ	Max	Unit
f_{ref}	reference frequency	input	-	-	250	MHz
$f_{o(max)}$	maximum output frequency	÷ 1 output; FSELx = 0	0	-	250	MHz
		÷ 2 output; FSELx = 1	0	-	125	MHz
δ_{ref}	reference duty cycle	input	25	-	75	%
t_{PLH}	LOW-to-HIGH propagation delay	CLKn to any Q	1.8	2.4	4.2	ns
t_{PHL}	HIGH-to-LOW propagation delay	CLKn to any Q	2.2	3.1	4.2	ns
t_{PLZ}	LOW to OFF-state propagation delay		-	-	10	ns
t_{PHZ}	HIGH to OFF-state propagation delay		-	-	10	ns
t_{PZL}	OFF-state to LOW propagation delay		-	-	10	ns
t_{PZH}	OFF-state to HIGH propagation delay		-	-	10	ns
$t_{sk(o)}$	output skew time	output-to-output				
		within one bank	-	-	150	ps
		any output bank, same output divider	-	-	200	ps
		any output, any output divider	-	-	1.2	ns
$t_{sk(pr)}$	process skew time	part-to-part	-	-	2.2	ns
$t_{sk(p)}$	pulse skew time	output	-	-	500	ps
δ_o	output duty cycle	÷ 1 output; $\delta_{ref} = 50\%$	45	50	55	%
		÷ 2 output; $\delta_{ref} = 25\%$ to 75%	45	50	55	%
t_r	rise time	input; CLK0, CLK1; 0.8 V to 2.0 V	-	-	3.0	ns
		output; 0.55 V to 2.4 V	0.1	-	1.0	ns
t_f	fall time	input; CLK0, CLK1; 2.0 V to 0.8 V	-	-	3.0	ns
		output; 2.4 V to 0.55 V	0.1	-	1.0	ns

[1] Dynamic (AC) characteristics apply for parallel output termination of 50 Ω to V_T .

Table 10. Dynamic characteristics (2.5 V)

$T_{amb} = -40\text{ }^{\circ}\text{C}$ to $+85\text{ }^{\circ}\text{C}$; $V_{CC} = V_{CC(bankA)} = V_{CC(bankB)} = V_{CC(bankC)} = 2.5\text{ V} \pm 5\%$.^[1]

Symbol	Parameter	Conditions	Min	Typ	Max	Unit
f_{ref}	reference frequency	input	0	250	-	MHz
$f_{o(max)}$	maximum output frequency	$\div 1$ output; FSELx = 0	0	250	-	MHz
		$\div 2$ output; FSELx = 1	0	125	-	MHz
δ_{ref}	reference duty cycle	input	25	-	75	%
t_{PLH}	LOW-to-HIGH propagation delay	CLKn to any Q	2.2	-	5.0	ns
t_{PHL}	HIGH-to-LOW propagation delay	CLKn to any Q	2.2	-	5.0	ns
t_{PLZ}	LOW to OFF-state propagation delay				10	ns
t_{PHZ}	HIGH to OFF-state propagation delay				10	ns
t_{PZL}	OFF-state to LOW propagation delay				10	ns
t_{PZH}	OFF-state to HIGH propagation delay				10	ns
$t_{sk(o)}$	output skew time	output-to-output				
		within one bank	-	-	150	ps
		any output bank, same output divider	-	-	200	ps
		any output, any output divider	-	-	1.2	ns
$t_{sk(pr)}$	process skew time	part-to-part	-	-	3.0	ns
$t_{sk(p)}$	pulse skew time	output	-	-	500	ps
δ_o	output duty cycle	$\div 1$ or $\div 2$ output; $\delta_{ref} = 50\%$	45	50	55	%
t_r	rise time	input; CLK0, CLK1; 0.7 V to 1.7 V	-	-	3.0	ns
		output; 0.6 V to 1.8 V	0.1	-	1.0	ns
t_f	fall time	input; CLK0, CLK1; 1.7 V to 0.7 V	-	-	3.0	ns
		output; 1.8 V to 0.6 V	0.1	-	1.0	ns

[1] Dynamic (AC) characteristics apply for parallel output termination of 50 Ω to V_T .

Table 11. Dynamic characteristics (mixed supply voltages)

$T_{amb} = -40\text{ }^{\circ}\text{C}$ to $+85\text{ }^{\circ}\text{C}$; $V_{CC} = 3.3 \pm 5\%$; any $V_{CC(bankA)}$, $V_{CC(bankB)}$, $V_{CC(bankC)} = 2.5\text{ V} \pm 5\%$ or $3.3\text{ V} \pm 5\%$.^{[1][2]}

Symbol	Parameter	Conditions	Min	Typ	Max	Unit
$t_{sk(o)}$	output skew time	output-to-output				
		within one bank	-	-	150	ps
		any output bank; same output divider	-	-	200	ps
		any output; any output divider	-	-	1.2	ns
$t_{sk(pr)}$	process skew time	part-to-part	-	-	3.0	ns
$t_{sk(p)}$	pulse skew time	output	-	-	500	ps
δ_o	output duty cycle	$\div 1$ or $\div 2$ output; $\delta_{ref} = 50\%$	45	50	55	%

[1] Dynamic (AC) characteristics apply for parallel output termination of 50 Ω to V_T .

[2] For all other dynamic (AC) specifications, refer to 2.5 V or 3.3 V tables according to the supply voltage of the output bank.

11. Application information

11.1 Driving transmission lines

The PCK9446 clock driver was designed to drive high speed signals in a terminated transmission line environment. To provide the optimum flexibility to the user the output drivers were designed to exhibit the lowest impedance possible. With an output impedance of less than $20\ \Omega$ the drivers can drive either parallel or series terminated transmission lines.

In most high performance clock networks point-to-point distribution of signals is the method of choice. In a point-to-point scheme either series terminated or parallel terminated transmission lines can be used. The parallel technique terminates the signal at the end of the line with a $50\ \Omega$ resistance to $0.5V_{CC}$. This technique draws a fairly high level of DC current and thus only a single terminated line can be driven by each output of the PCK9446 clock driver. For the series terminated case however there is no DC current draw, thus the outputs can drive multiple series terminated lines. [Figure 3](#), illustrates an output driving a single series terminated line versus two series terminated lines in parallel. When taken to its extreme, the fan-out of the PCK9446 clock driver is effectively doubled due to its capability to drive multiple lines.

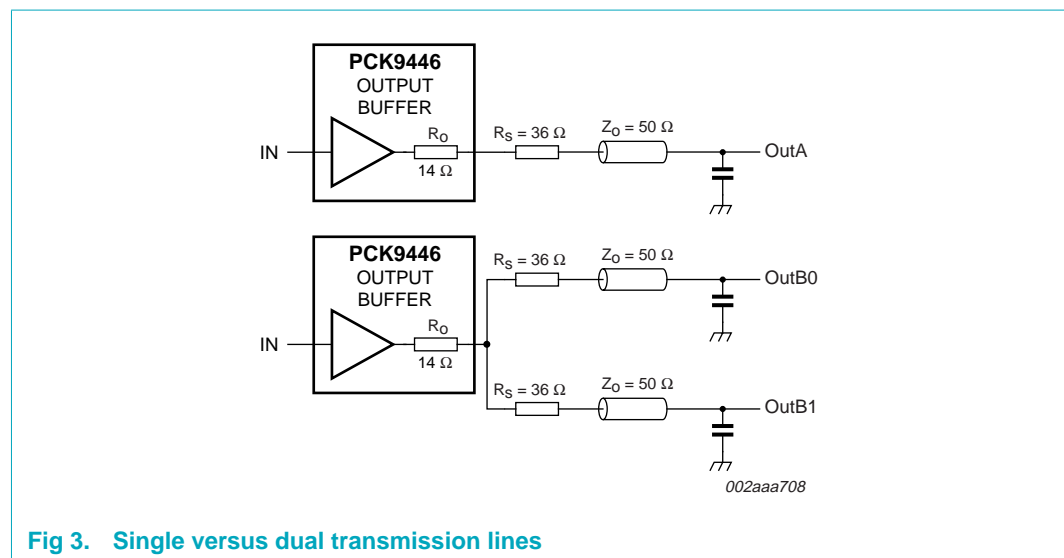

Fig 3. Single versus dual transmission lines

The waveform plots of [Figure 4](#) show simulation results of an output driving a single line versus two lines. In both cases the drive capability of the PCK9446 output buffer is more than sufficient to drive 50 Ω transmission lines on the incident edge. Note from the delay measurements in the simulations a delta of only 43 ps exists between the two differently loaded outputs. This suggests that the dual line driving need not be used exclusively to maintain the tight output-to-output skew of the PCK9446. The output waveform in [Figure 4](#) shows a step in the waveform; this step is caused by the impedance mismatch seen looking into the driver. The parallel combination of the 36 Ω series resistor plus the output impedance does not match the parallel combination of the line impedances. The voltage wave launched down the two lines will equal:

$$V_L = V_s \left(\frac{Z_o}{R_s + R_o + Z_o} \right) = 3.0 \left(\frac{25}{18 + 17 + 25} \right) = 1.25 \text{ V}$$

$$Z_o = 50 \text{ } \Omega \parallel 50 \text{ } \Omega$$

$$R_s = 36 \text{ } \Omega \parallel 36 \text{ } \Omega$$

$$R_o = 17 \text{ } \Omega$$

At the load end the voltage will double, due to the near unity reflection coefficient, to 2.5 V. It will then increment towards the quiescent 3.0 V in steps separated by one round trip delay (in this case 4.0 ns).

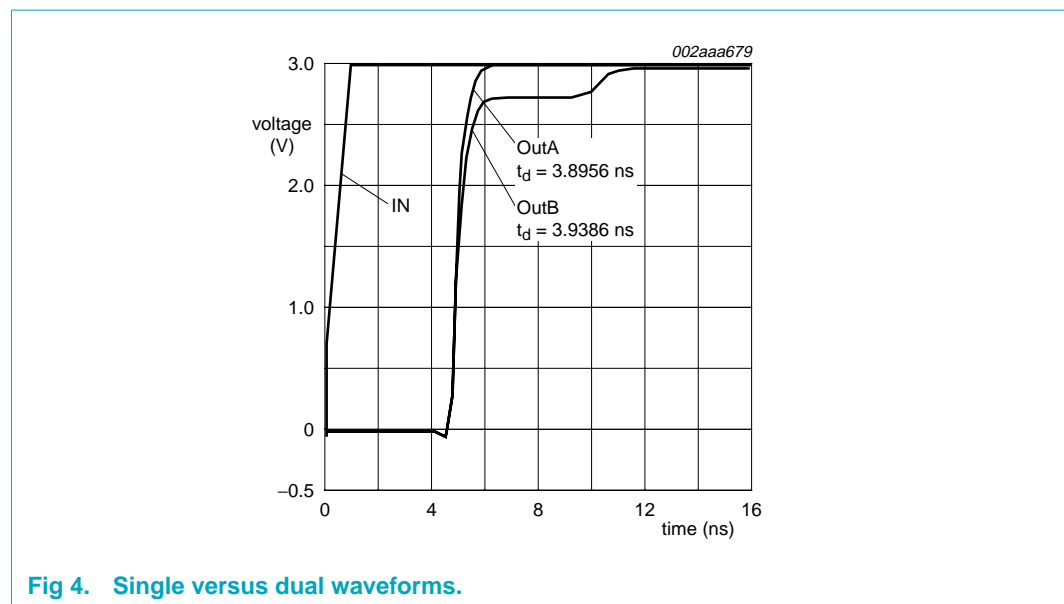
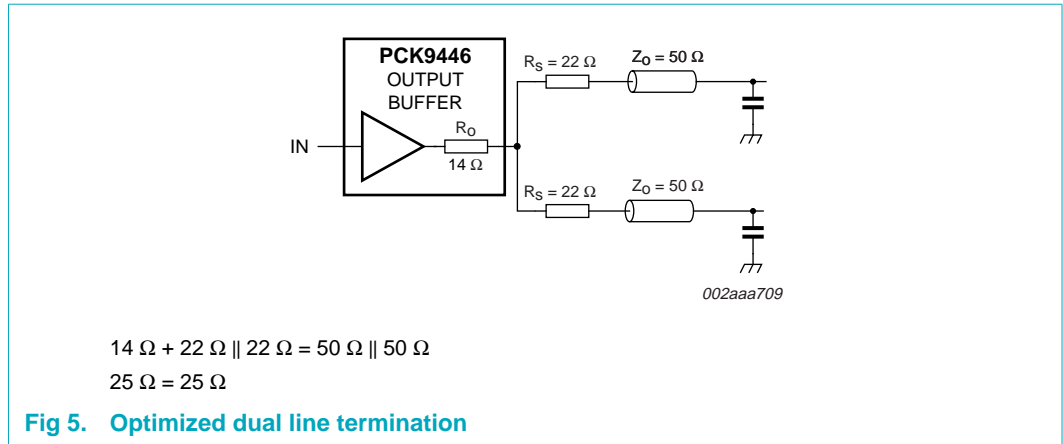
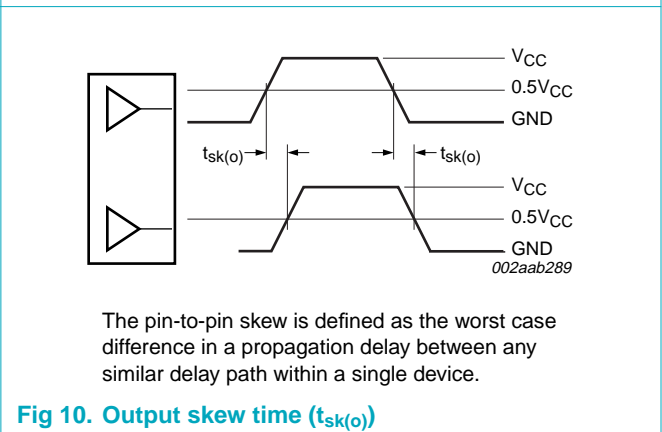
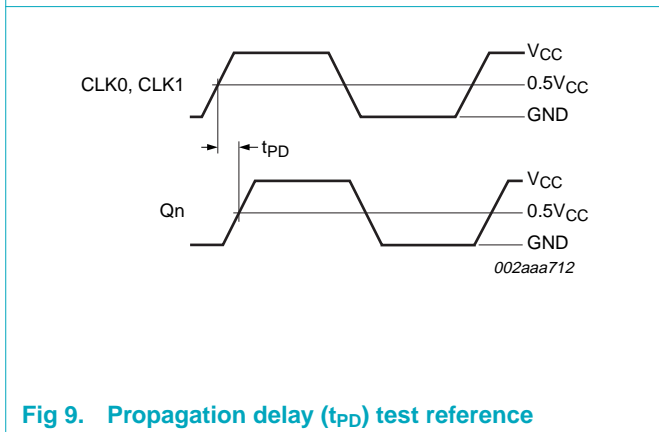
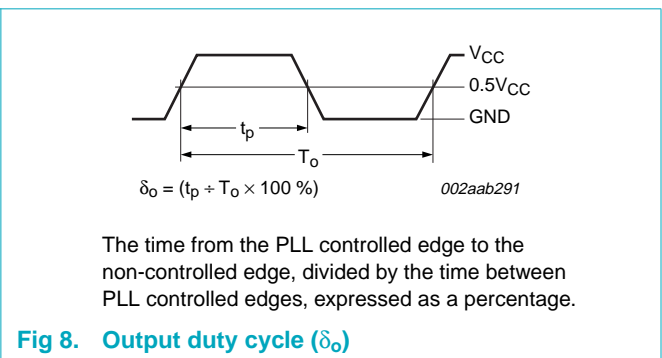
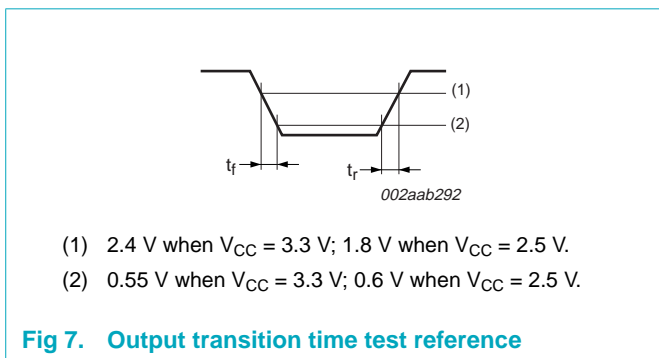
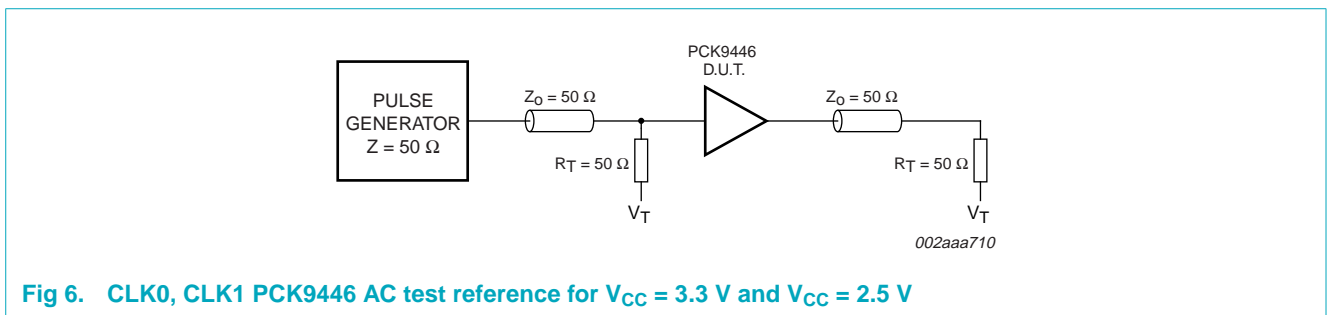

Fig 4. Single versus dual waveforms.

Since this step is well above the threshold region it will not cause any false clock triggering, however designers may be uncomfortable with unwanted reflections on the line. To better match the impedances when driving multiple lines, the situation in [Figure 5](#) should be used. In this case the series terminating resistors are reduced such that when the parallel combination is added to the output buffer impedance the line impedance is perfectly matched.



12. Test information



13. Package outline

LQFP32: plastic low profile quad flat package; 32 leads; body 7 x 7 x 1.4 mm

SOT358-1

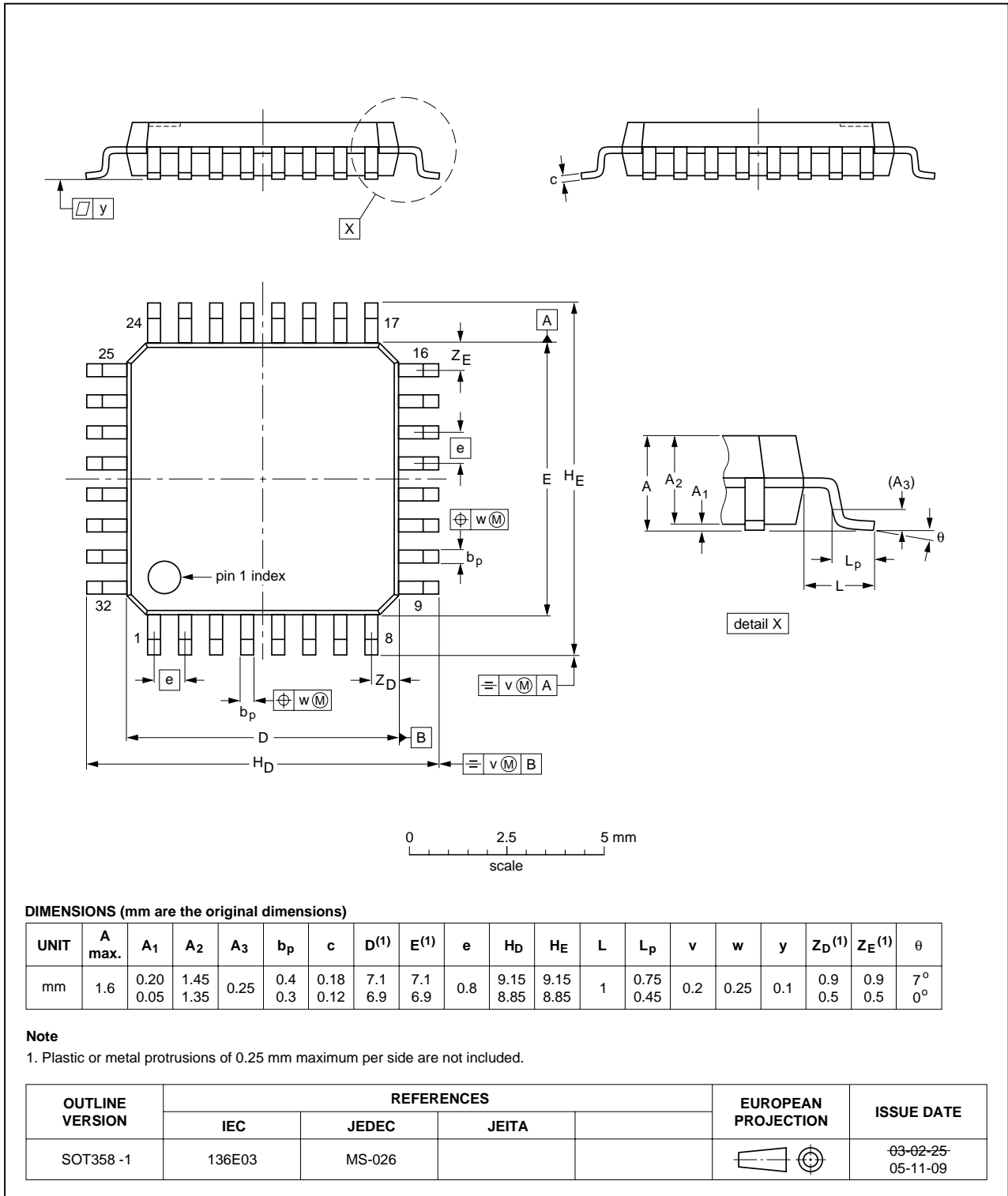

Fig 11. Package outline SOT358-1 (LQFP32)

14. Soldering

14.1 Introduction to soldering surface mount packages

This text gives a very brief insight to a complex technology. A more in-depth account of soldering ICs can be found in our *Data Handbook IC26; Integrated Circuit Packages* (document order number 9398 652 90011).

There is no soldering method that is ideal for all surface mount IC packages. Wave soldering can still be used for certain surface mount ICs, but it is not suitable for fine pitch SMDs. In these situations reflow soldering is recommended.

14.2 Reflow soldering

Reflow soldering requires solder paste (a suspension of fine solder particles, flux and binding agent) to be applied to the printed-circuit board by screen printing, stencilling or pressure-syringe dispensing before package placement. Driven by legislation and environmental forces the worldwide use of lead-free solder pastes is increasing.

Several methods exist for reflowing; for example, convection or convection/infrared heating in a conveyor type oven. Throughput times (preheating, soldering and cooling) vary between 100 seconds and 200 seconds depending on heating method.

Typical reflow peak temperatures range from 215 °C to 270 °C depending on solder paste material. The top-surface temperature of the packages should preferably be kept:

- below 225 °C (SnPb process) or below 245 °C (Pb-free process)
 - for all BGA, HTSSON..T and SSOP..T packages
 - for packages with a thickness ≥ 2.5 mm
 - for packages with a thickness < 2.5 mm and a volume ≥ 350 mm³ so called thick/large packages.
- below 240 °C (SnPb process) or below 260 °C (Pb-free process) for packages with a thickness < 2.5 mm and a volume < 350 mm³ so called small/thin packages.

Moisture sensitivity precautions, as indicated on packing, must be respected at all times.

14.3 Wave soldering

Conventional single wave soldering is not recommended for surface mount devices (SMDs) or printed-circuit boards with a high component density, as solder bridging and non-wetting can present major problems.

To overcome these problems the double-wave soldering method was specifically developed.

If wave soldering is used the following conditions must be observed for optimal results:

- Use a double-wave soldering method comprising a turbulent wave with high upward pressure followed by a smooth laminar wave.
- For packages with leads on two sides and a pitch (e):
 - larger than or equal to 1.27 mm, the footprint longitudinal axis is **preferred** to be parallel to the transport direction of the printed-circuit board;

- smaller than 1.27 mm, the footprint longitudinal axis **must** be parallel to the transport direction of the printed-circuit board.

The footprint must incorporate solder thieves at the downstream end.

- For packages with leads on four sides, the footprint must be placed at a 45° angle to the transport direction of the printed-circuit board. The footprint must incorporate solder thieves downstream and at the side corners.

During placement and before soldering, the package must be fixed with a droplet of adhesive. The adhesive can be applied by screen printing, pin transfer or syringe dispensing. The package can be soldered after the adhesive is cured.

Typical dwell time of the leads in the wave ranges from 3 seconds to 4 seconds at 250 °C or 265 °C, depending on solder material applied, SnPb or Pb-free respectively.

A mildly-activated flux will eliminate the need for removal of corrosive residues in most applications.

14.4 Manual soldering

Fix the component by first soldering two diagonally-opposite end leads. Use a low voltage (24 V or less) soldering iron applied to the flat part of the lead. Contact time must be limited to 10 seconds at up to 300 °C.

When using a dedicated tool, all other leads can be soldered in one operation within 2 seconds to 5 seconds between 270 °C and 320 °C.

14.5 Package related soldering information

Table 12. Suitability of surface mount IC packages for wave and reflow soldering methods

Package ^[1]	Soldering method	
	Wave	Reflow ^[2]
BGA, HTSSON..T ^[3] , LBGA, LFBGA, SQFP, SSOP..T ^[3] , TFBGA, VFBGA, XSON	not suitable	suitable
DHVQFN, HBCC, HBGA, HLQFP, HSO, HSOP, HSQFP, HSSON, HTQFP, HTSSOP, HVQFN, HVSON, SMS	not suitable ^[4]	suitable
PLCC ^[5] , SO, SOJ	suitable	suitable
LQFP, QFP, TQFP	not recommended ^{[5][6]}	suitable
SSOP, TSSOP, VSO, VSSOP	not recommended ^[7]	suitable
CWQCCN..L ^[8] , PMFP ^[9] , WQCCN..L ^[8]	not suitable	not suitable

[1] For more detailed information on the BGA packages refer to the *(LF)BGA Application Note (AN01026)*; order a copy from your Philips Semiconductors sales office.

[2] All surface mount (SMD) packages are moisture sensitive. Depending upon the moisture content, the maximum temperature (with respect to time) and body size of the package, there is a risk that internal or external package cracks may occur due to vaporization of the moisture in them (the so called popcorn effect). For details, refer to the Drypack information in the *Data Handbook IC26; Integrated Circuit Packages; Section: Packing Methods*.

[3] These transparent plastic packages are extremely sensitive to reflow soldering conditions and must on no account be processed through more than one soldering cycle or subjected to infrared reflow soldering with peak temperature exceeding 217 °C ± 10 °C measured in the atmosphere of the reflow oven. The package body peak temperature must be kept as low as possible.

- [4] These packages are not suitable for wave soldering. On versions with the heatsink on the bottom side, the solder cannot penetrate between the printed-circuit board and the heatsink. On versions with the heatsink on the top side, the solder might be deposited on the heatsink surface.
- [5] If wave soldering is considered, then the package must be placed at a 45° angle to the solder wave direction. The package footprint must incorporate solder thieves downstream and at the side corners.
- [6] Wave soldering is suitable for LQFP, QFP and TQFP packages with a pitch (e) larger than 0.8 mm; it is definitely not suitable for packages with a pitch (e) equal to or smaller than 0.65 mm.
- [7] Wave soldering is suitable for SSOP, TSSOP, VSO and VSSOP packages with a pitch (e) equal to or larger than 0.65 mm; it is definitely not suitable for packages with a pitch (e) equal to or smaller than 0.5 mm.
- [8] Image sensor packages in principle should not be soldered. They are mounted in sockets or delivered pre-mounted on flex foil. However, the image sensor package can be mounted by the client on a flex foil by using a hot bar soldering process. The appropriate soldering profile can be provided on request.
- [9] Hot bar soldering or manual soldering is suitable for PMFP packages.

15. Abbreviations

Table 13. Abbreviations

Acronym	Description
LVCMOS	Low Voltage Complementary Metal Oxide Silicon
LVPECL	Low Voltage Positive Emitter Coupled Logic

16. Revision history

Table 14. Revision history

Document ID	Release date	Data sheet status	Change notice	Supersedes
PCK9446_1 (9397 750 12485)	20060410	Product data sheet	-	-

17. Legal information

17.1 Data sheet status

Document status ^{[1][2]}	Product status ^[3]	Definition
Objective [short] data sheet	Development	This document contains data from the objective specification for product development.
Preliminary [short] data sheet	Qualification	This document contains data from the preliminary specification.
Product [short] data sheet	Production	This document contains the product specification.

[1] Please consult the most recently issued document before initiating or completing a design.

[2] The term 'short data sheet' is explained in section "Definitions".

[3] The product status of device(s) described in this document may have changed since this document was published and may differ in case of multiple devices. The latest product status information is available on the Internet at URL <http://www.semiconductors.philips.com>.

17.2 Definitions

Draft — The document is a draft version only. The content is still under internal review and subject to formal approval, which may result in modifications or additions. Philips Semiconductors does not give any representations or warranties as to the accuracy or completeness of information included herein and shall have no liability for the consequences of use of such information.

Short data sheet — A short data sheet is an extract from a full data sheet with the same product type number(s) and title. A short data sheet is intended for quick reference only and should not be relied upon to contain detailed and full information. For detailed and full information see the relevant full data sheet, which is available on request via the local Philips Semiconductors sales office. In case of any inconsistency or conflict with the short data sheet, the full data sheet shall prevail.

17.3 Disclaimers

General — Information in this document is believed to be accurate and reliable. However, Philips Semiconductors does not give any representations or warranties, expressed or implied, as to the accuracy or completeness of such information and shall have no liability for the consequences of use of such information.

Right to make changes — Philips Semiconductors reserves the right to make changes to information published in this document, including without limitation specifications and product descriptions, at any time and without notice. This document supersedes and replaces all information supplied prior to the publication hereof.

Suitability for use — Philips Semiconductors products are not designed, authorized or warranted to be suitable for use in medical, military, aircraft, space or life support equipment, nor in applications where failure or

malfunction of a Philips Semiconductors product can reasonably be expected to result in personal injury, death or severe property or environmental damage. Philips Semiconductors accepts no liability for inclusion and/or use of Philips Semiconductors products in such equipment or applications and therefore such inclusion and/or use is for the customer's own risk.

Applications — Applications that are described herein for any of these products are for illustrative purposes only. Philips Semiconductors makes no representation or warranty that such applications will be suitable for the specified use without further testing or modification.

Limiting values — Stress above one or more limiting values (as defined in the Absolute Maximum Ratings System of IEC 60134) may cause permanent damage to the device. Limiting values are stress ratings only and operation of the device at these or any other conditions above those given in the Characteristics sections of this document is not implied. Exposure to limiting values for extended periods may affect device reliability.

Terms and conditions of sale — Philips Semiconductors products are sold subject to the general terms and conditions of commercial sale, as published at <http://www.semiconductors.philips.com/profile/terms>, including those pertaining to warranty, intellectual property rights infringement and limitation of liability, unless explicitly otherwise agreed to in writing by Philips Semiconductors. In case of any inconsistency or conflict between information in this document and such terms and conditions, the latter will prevail.

No offer to sell or license — Nothing in this document may be interpreted or construed as an offer to sell products that is open for acceptance or the grant, conveyance or implication of any license under any copyrights, patents or other industrial or intellectual property rights.

17.4 Trademarks

Notice: All referenced brands, product names, service names and trademarks are the property of their respective owners.

18. Contact information

For additional information, please visit: <http://www.semiconductors.philips.com>

For sales office addresses, send an email to: sales.addresses@www.semiconductors.philips.com

19. Contents

1	General description	1
2	Features	1
3	Ordering information	2
4	Functional diagram	2
5	Pinning information	3
5.1	Pinning	3
5.2	Pin description	3
6	Functional description	4
6.1	Function table	4
6.2	Supply configurations	4
7	Limiting values	5
8	Recommended operating conditions	5
9	Static characteristics	6
10	Dynamic characteristics	7
11	Application information	9
11.1	Driving transmission lines	9
12	Test information	11
13	Package outline	12
14	Soldering	13
14.1	Introduction to soldering surface mount packages	13
14.2	Reflow soldering	13
14.3	Wave soldering	13
14.4	Manual soldering	14
14.5	Package related soldering information	14
15	Abbreviations	15
16	Revision history	15
17	Legal information	16
17.1	Data sheet status	16
17.2	Definitions	16
17.3	Disclaimers	16
17.4	Trademarks	16
18	Contact information	16
19	Contents	17

Please be aware that important notices concerning this document and the product(s) described herein, have been included in section 'Legal information'.



© Koninklijke Philips Electronics N.V. 2006. All rights reserved.

For more information, please visit: <http://www.semiconductors.philips.com>.

For sales office addresses, email to: sales.addresses@www.semiconductors.philips.com.

Date of release: 10 April 2006

Document identifier: PCK9446_1